

V-TAC

Meaningful Innovation.

WEEE Number: 80133970

INSTRUCTION MANUAL LED HIGHBAY

TECHNICAL DATA

MODEL	VT-91101	VT-91200
SKU	10035, 10040	10041, 10042
WATTS	100W	200W
LUMENS @WIDE CONE	8700LM	17540LM
BEAM ANGLE	115°	115°
CRI	>70	>70
DF	>0.9	>0.9
SAFETY CLASS	Class I	Class I
OPERATION TEMPERATURE	-20° to +45°C	-20° to +45°C
DIMENSION	230.4x80mm	326x86.8mm
INPUT POWER	AC:220-240V,50/60Hz	AC:220-240V,50/60Hz
LIFE SPAN [Hours]	25000	25000
N.W (KGS)	0.979	1.9425
MAX MOUNTING HEIGHT	<5M	<5M

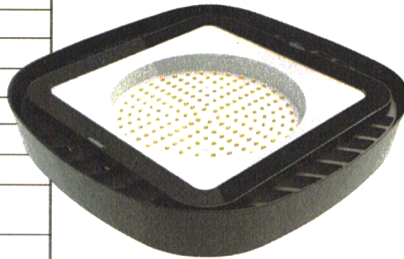

**IP65
RATING**

**02
YEAR
WARRANTY***

INTRODUCTION & WARRANTY

Thank you for selecting and buying V-TAC product. V-TAC will serve you the best. Please read these instructions carefully before starting the installation and keep this manual handy for future reference. If you have any another query, please contact our dealer or local vendor from whom you have purchased the product. They are trained and ready to serve you at the best. The warranty is valid for 2 years from the date of purchase. The warranty does not apply to damage caused by incorrect installation or abnormal wear and tear. The company gives no warranty against damage to any surface due to incorrect removal and installation of the product. The products are suitable for 10-12 Hours Daily operation. Usage of product for 24 Hours a day would void the warranty. This product is warranted for manufacturing defects only.



This marking indicates that this product should not be disposed of with other household wastes.



Caution, risk of electric shock.



MULTI-LANGUAGE MANUAL QR CODE

Please scan the QR code to access the manual in multiple languages.

WARNING

- Please make sure to turn off the power before starting the installation.
- Installation must be performed by a qualified electrician.
- The light source of this luminaire is not replaceable, when the light source reaches its end of life the whole luminaire should be replaced.
- If the external flexible cable or cord of this luminaire is damaged, it shall be exclusively replaced by the manufacturer or his service agent or a similar qualified person in order to avoid a hazard.
- Proper grounding should be ensured throughout the installation.
- Terminal block not included.
- To be connected with waterproof cable hose.
- Replace any cracked protective shield.
- Minimum distance from lighted objects 1m.

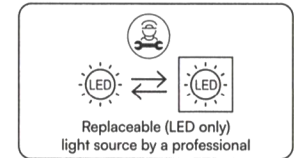

*This product contains a light source of energy efficiency class<F>, where <F> shall be replaced by the energy class of the contained light source.

INSTALLATION DIAGRAM

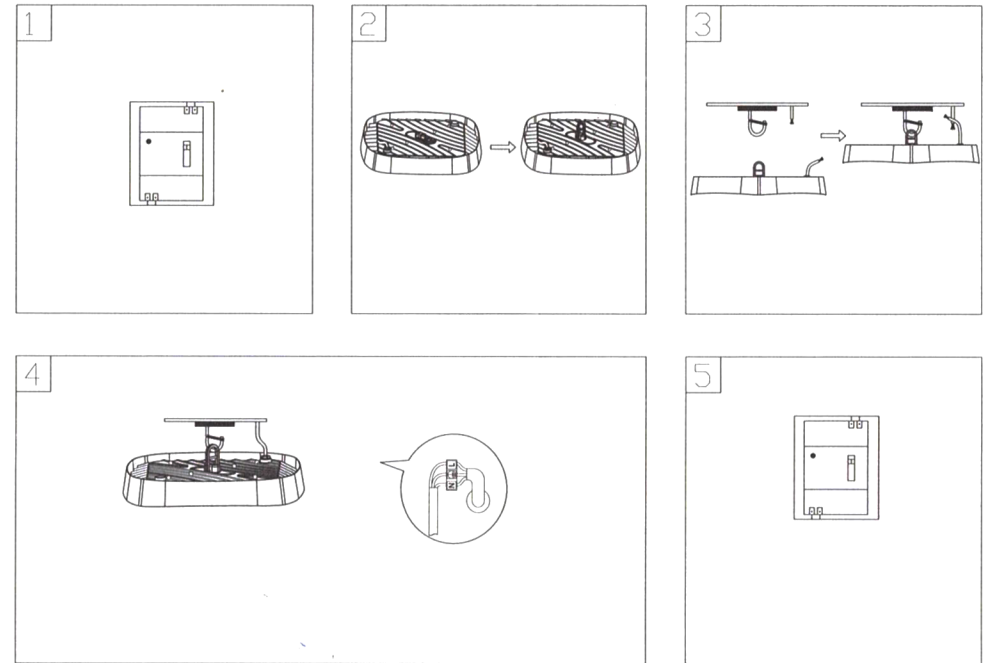

INSTALLATION INSTRUCTION

- Step 1:** Switch OFF the power
- Step 2:** Open the hidden hook
- Step 3:** Hang the lamp on a hook
- Step 4:** Connect L, N and \ominus Wires
- Step 5:** Switch ON the power and test

DISASSEMBLY DIAGRAM

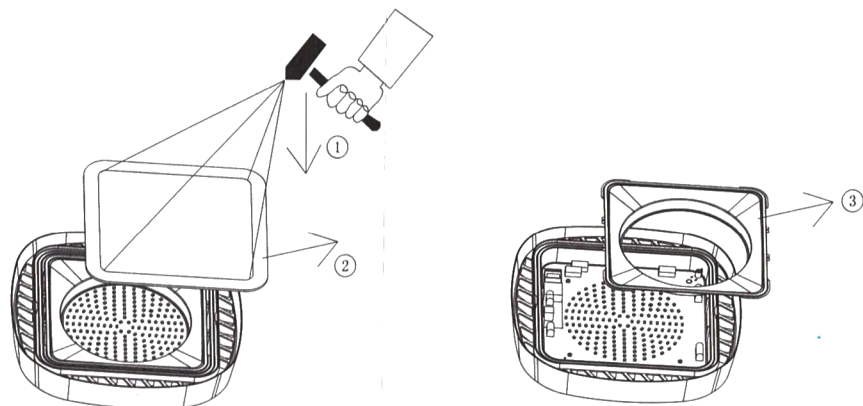

RoHS



IN CASE OF ANY QUERY/ISSUE WITH THE PRODUCT, PLEASE REACH OUT TO US AT: SUPPORT@V-TAC.EU
FOR MORE PRODUCTS RANGE, INQUIRY PLEASE CONTACT OUR DISTRIBUTOR OR NEAREST DEALERS.
V-TAC EUROPE LTD. BULGARIA, PLOVDIV 4000, BUL.L.KARAVELOW 9B