

Specific for Australia

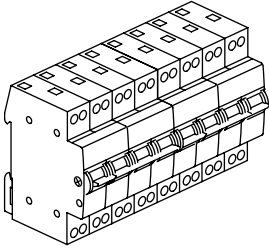

Modular changeover 63A
with centre OFF position



6S5503d

SF463

Alternative supply generator: typical location of manual changeover device with centre "off" position in the main switch board.

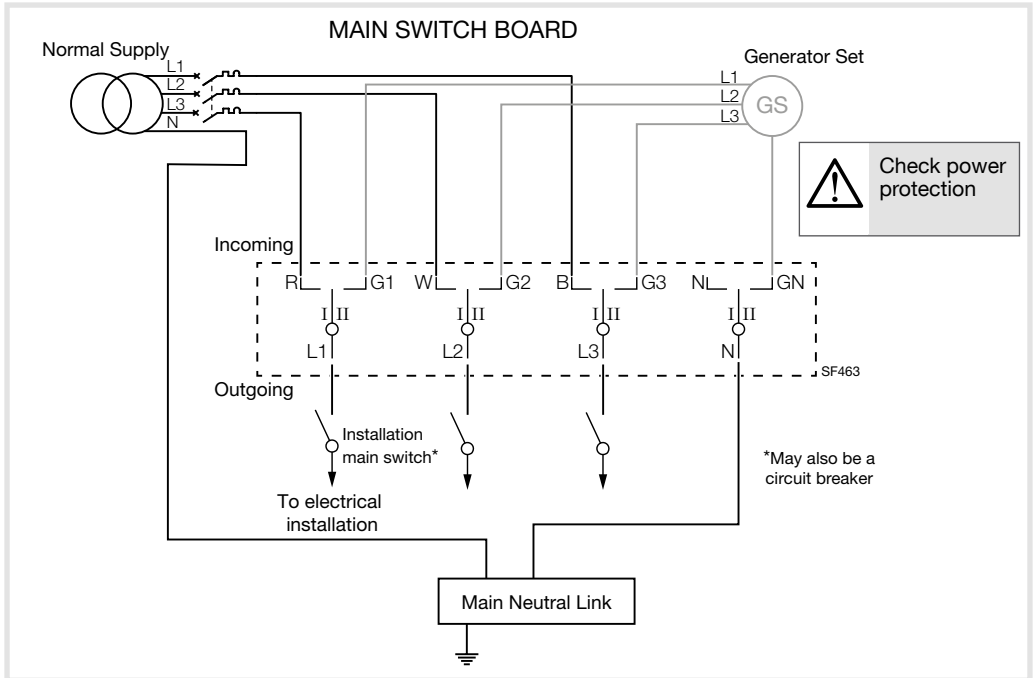

This modular changeover switch is not a disconnecter. The isolation must be ensured with an appropriate device. The changeover incoming must be protected against short circuit with an appropriate MCB 63A - 6kA - C curve.

NOTE 1: In Australia and NZ, the Main Supply Neutral upstream of the MEN connection is NOT allowed to be switched. (AS/NZS 3010).

NOTE 2: Refer to AS/NZS 3000, 3010 and local Service and Installation Rules for specific requirements.